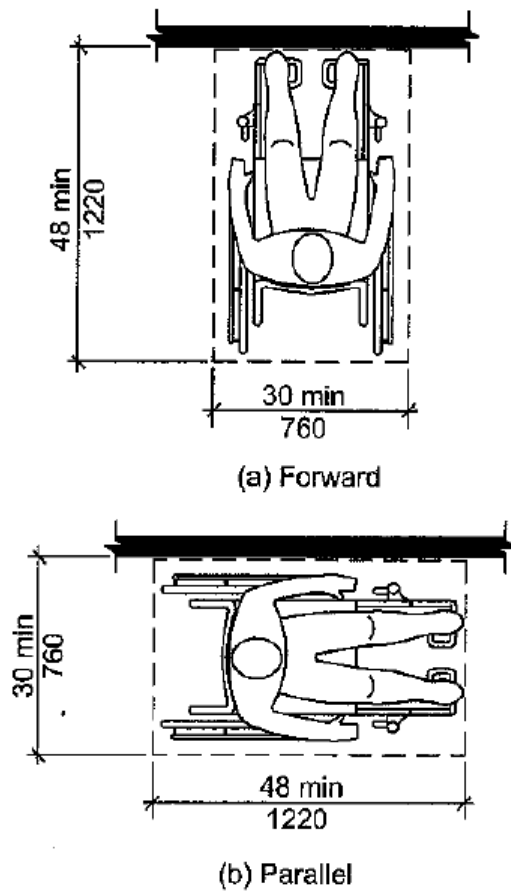
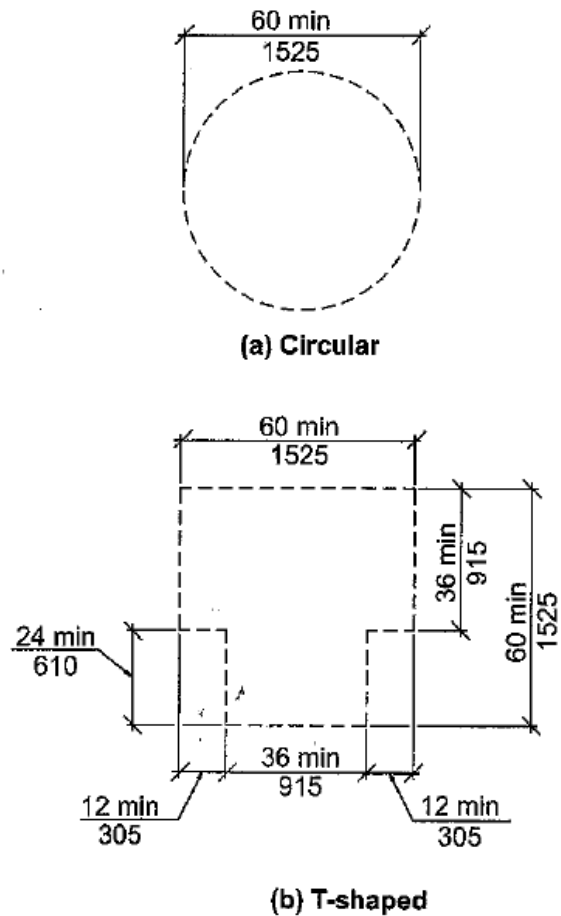

**FIGURE 305.3
SIZE OF CLEAR FLOOR SPACE**



**FIGURE 305.5
POSITION OF CLEAR FLOOR SPACE**



**FIGURE 304.3
SIZE OF TURNING SPACE**

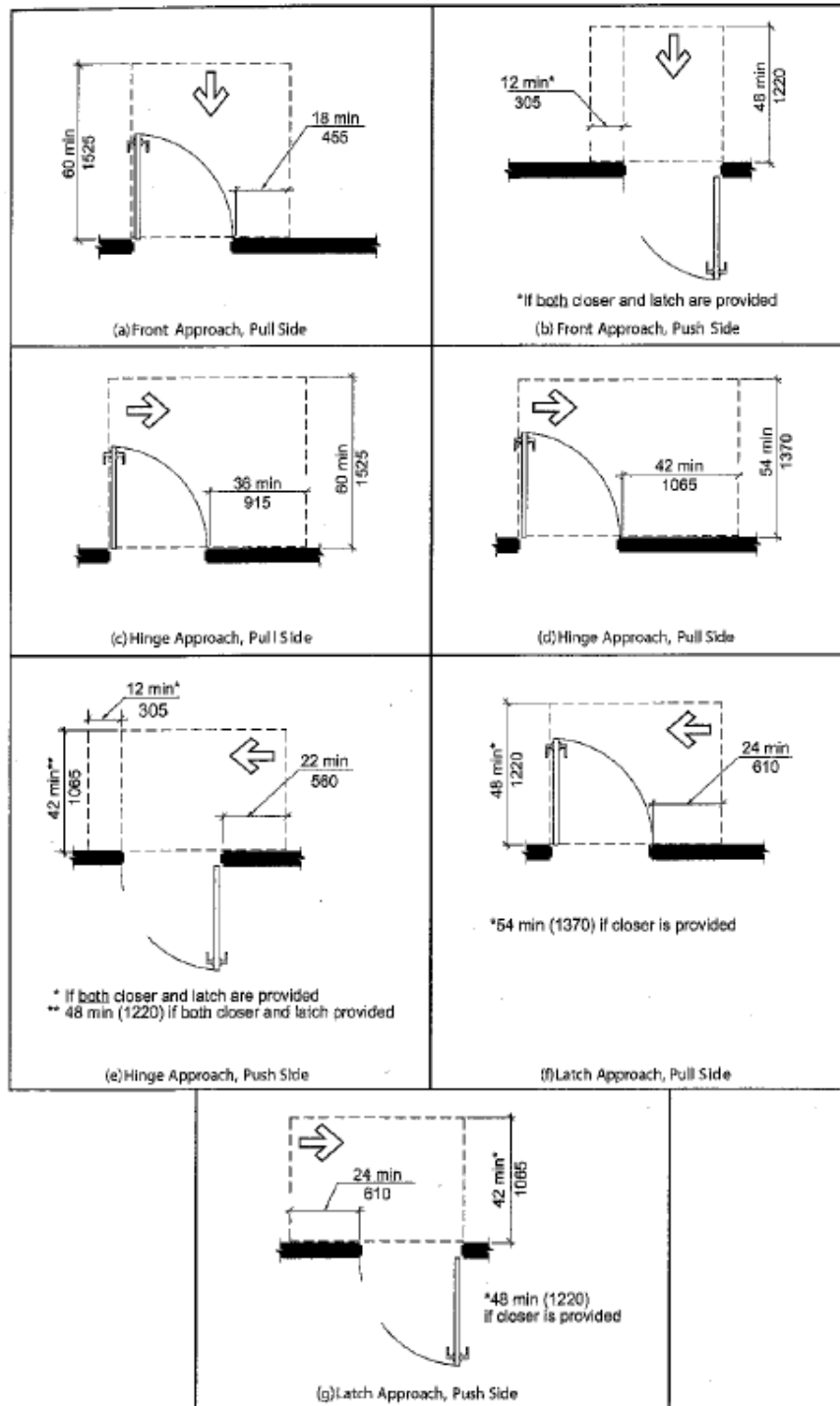

FIGURE 404.2.3.2
MANEUVERING CLEARANCE AT MANUAL SWINGING DOORS

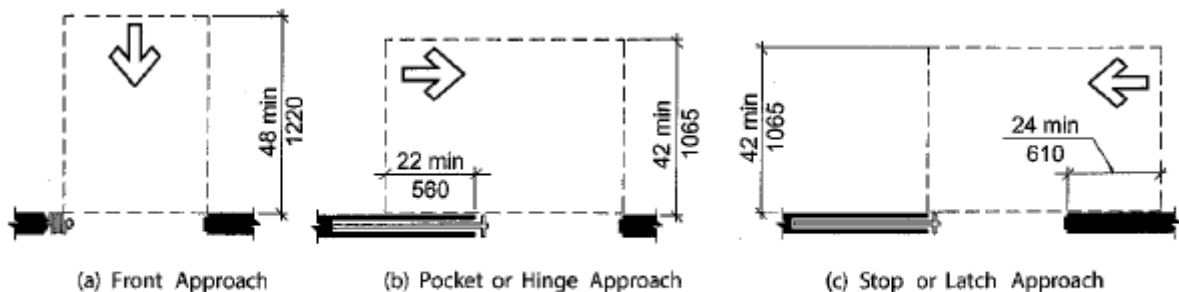

FIGURE 404.2.3.3
MANEUVERING CLEARANCE AT SLIDING AND FOLDING DOORS

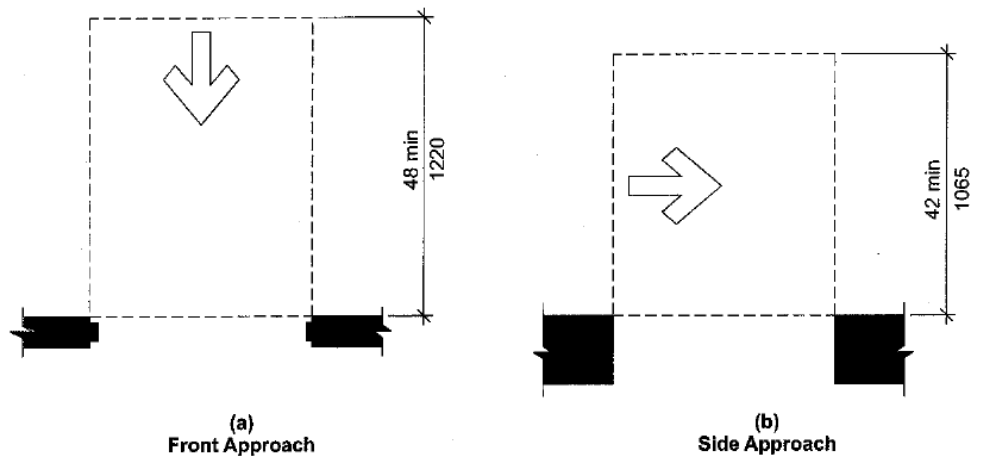

FIGURE 404.2.3.4
MANEUVERING CLEARANCE AT DOORWAYS WITHOUT DOORS

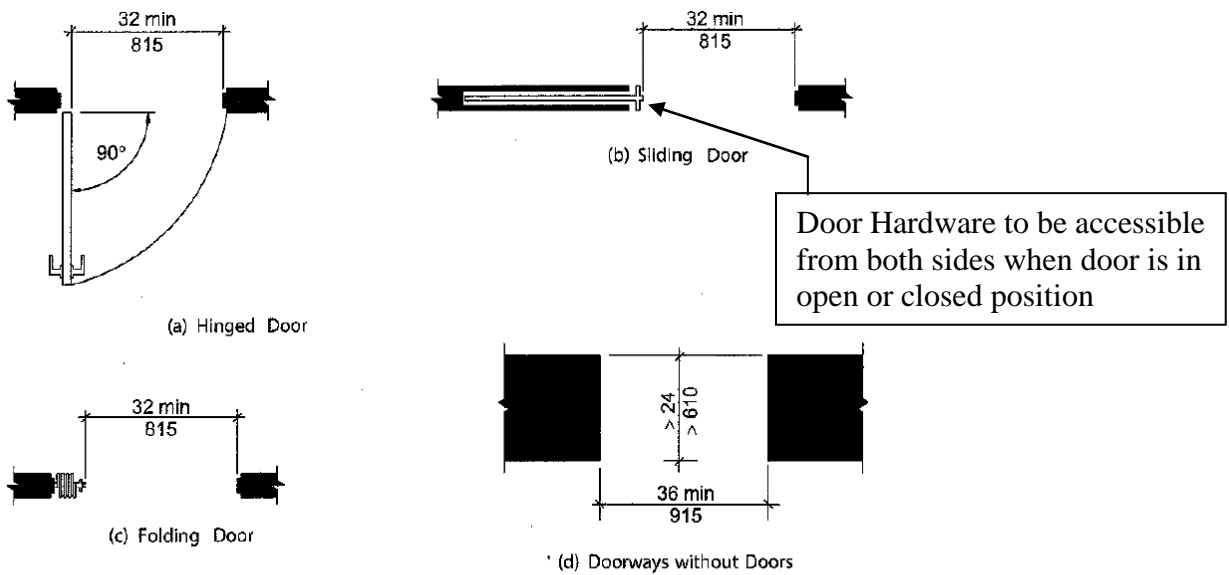

FIGURE 404.2.2
CLEAR WIDTH OF DOORWAYS

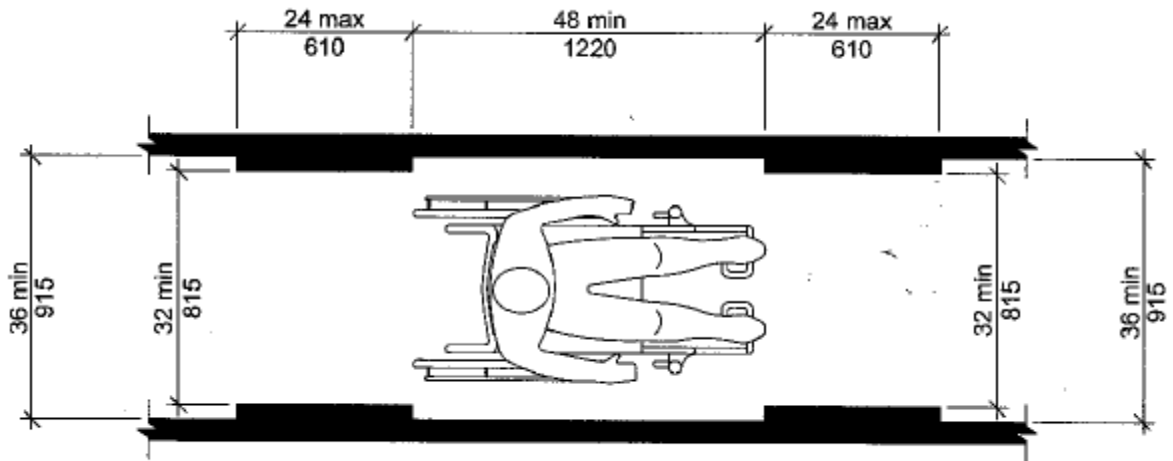

FIGURE 403.5
CLEAR WIDTH OF AN ACCESSIBLE ROUTE

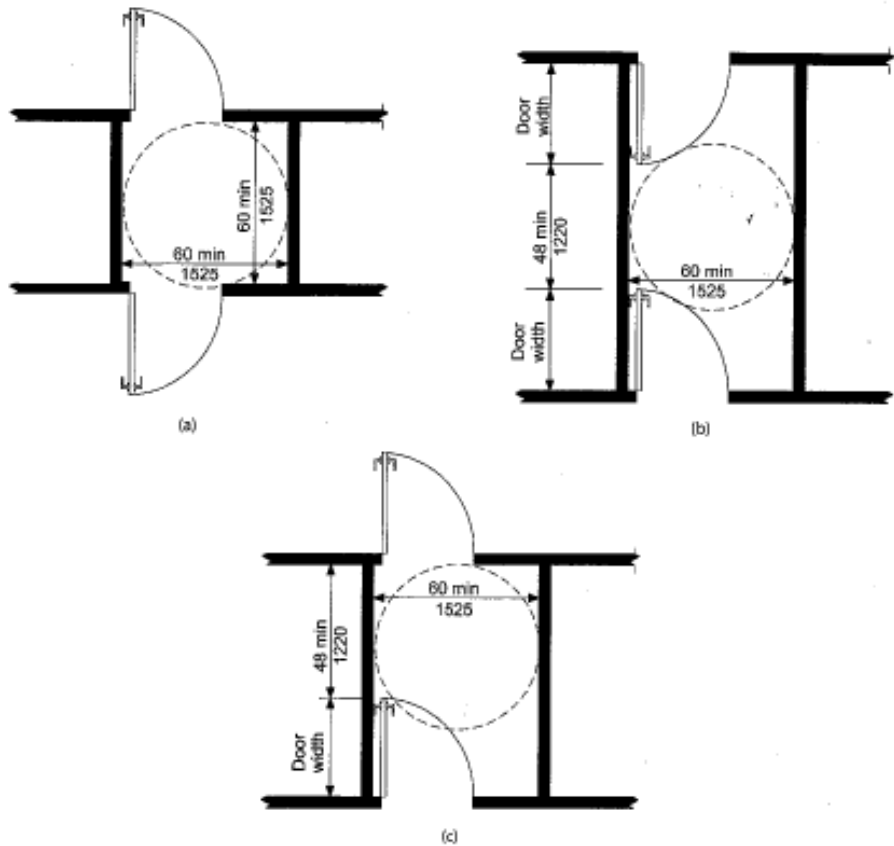

FIGURE 404.2.5
TWO DOORS IN A SERIES

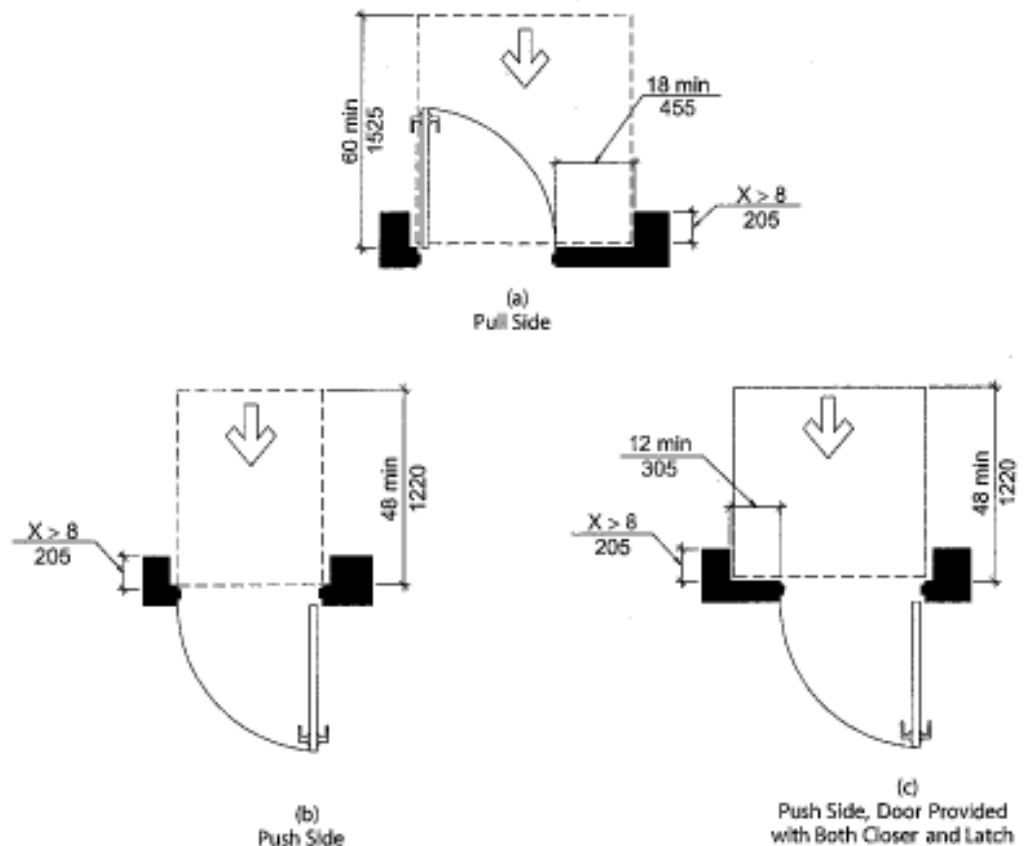

FIGURE 404.2.3.5
MANEUVERING CLEARANCE AT RECESSED DOORS